

EN

ITALVIBRAS ELECTROMAGNETIC VIBRATOR

NEW

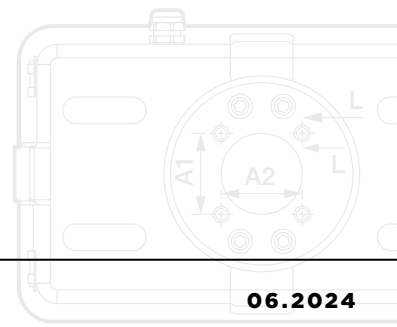

06.2024

VE

VE

THE ITALVIBRAS ELECTROMAGNETIC VIBRATOR

NEW

The choices made at the design level have allowed us to obtain a product with a large range of use and a wide possibility of adjustment.

In the new Italvibras electromagnetic vibrators the “passive” mass laying on the weight of the vibrating machine is very reduced, allowing a better operating

efficiency. Adjustment can be tuned with vibrator installed on the machine: no special tools needed.



TECHNICAL FEATURES

POWER SUPPLY

Single-phase / three-phase voltage from 105V to 600V, 25/50Hz (in 50Hz net) and 30/60Hz (in 60Hz net); frequency control system available on request.

FUNCTIONING

Continuous service (S1) or intermittent services, with immediate start/stop after switching.

RANGE OF APPLICATIONS

Wide range extended from 25 to 450 kg.

MECHANICAL PROTECTION

IP55 according to IEC/EN 60529;

PROTECTION AGAINST MECHANICAL IMPACTS

IK08 according to IEC/EN 62262;

INSULATION CLASS

Class F (155°C).

TROPICALIZATION

Standard on all vibrators, with vacuum encapsulated coil.

AMBIENT TEMPERATURE

From -20°C to +40°C. Versions for higher or lower temperatures are available on request.

THERMAL PROTECTION

Optionally.

FIXING OF THE VIBRATOR

In all positions and therefore without restriction. Small fixing foot.

CONNECTION

Supplied with 2m cable. Other connections available on request.

BASE

In cast iron.

COVER

In aluminium. Easy fitting. Protected from water and dust by seal.

MAGNET

Fully vacuum encapsulated in epoxy resin.

CERTIFICATION

Conformity with all applicable Directives. Version suitable for potentially explosive atmospheres.

SURFACE TREATMENT

As standard: electrostatic surface treatment based on polymerised epoxy polyester powder in oven at 200°C, tested in salt spray for 500 hours.

On request STEEL IT polyurethane resin coating also available.

Code	Type	Weight (Kg)	Power (KVA)	Working weight range (Kg)		Amplitude (mm)		Dimensional specifications (mm)								
				min	max	max	min	A	B	C	D	E	F	Fixing holes		
															A1	A2
609007	VE 50	62	0,8	25	100	2,1	0,9	135	366	266	219	18	M10	60	60	
609013	VE 75	70	0,9	50	100	1,9	1	135	366	266	219	18	M10	60	60	
609008	VE 100	128	1,8	75	150	1,7	1	165	460	365	270	20	M12	80	80	
609012	VE 150	150	1,8	100	200	1,9	1,2	165	460	365	270	20	M12	80	80	
609014	VE 200	230	2,7	180	250	1,8	1,4	210	547	431	354	26	M16x1,5	100	100	
609010	VE 250	237	3	200	320	1,9	1,4	210	547	431	354	26	M16x1,5	100	100	
609009	VE 300	272	3,5	200	400	2	1,3	210	547	431	354	26	M16x1,5	100	100	
609011	VE 350	305	3,7	250	450	2	1,3	210	547	455	354	26	M16x1,5	100	100	

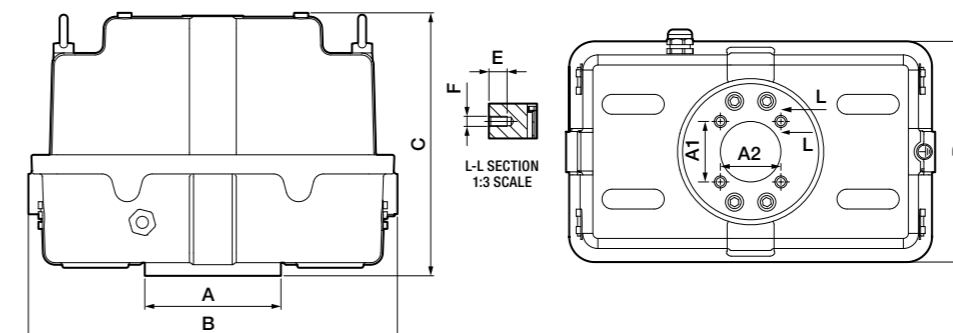

For further details please contact sales offices at Italvibras. The technical data and models listed in this catalogue are not binding. Italvibras reserves the right to modify them without prior notice.

■ **GERMANY**

ITALVIBRAS DEUTSCHLAND
Carl-Leverkus-Strasse, 20
40764 Langenfeld - Germany
tel. +49 2173 20446-0
fax +49 2173 20446-10
info@italvibrasdeutschland.com
www.italvibrasdeutschland.com

■ **FRANCE**

ITALVIBRAS FRANCE SAS
Zac Garosud - Toucan 34
256 Rue du Commandant Massoud
34070 Montpellier - France
tel. +33 0467 275400
fax +33 0467 474830
italvibrasfrance@italvibrasfrance.com
www.italvibrasfrance.com

■ **SPAIN**

ITALVIBRAS IBERICA S.L.
Pol. Ind. La Nava, calle G, nº12
31300 Tafalla (Navarra)
tel. +34 948 71 23 47
info@italvibrasiberica.com
www.italvibrasiberica.com

■ **UK**

VIBRATECHNIQUES LTD.
20 Cecil Pashley Way,
Shoreham Airport
Shoreham by Sea, Sussex
BN43 5FF.
tel. +44 01273 430977
fax +44 01273 430989
sales@vibtec.com
www.vibtec.com

■ **USA**

ITALVIBRAS USA INC.
1940 Vans Way Princeton, IL 61356
tel. +1 815 872 1350
fax +1 866 337 2693

ITALVIBRAS USA INC.
2451 Wright Blvd
Hebron, KY 41048
tel. +1 859 203 3222
fax +1 866 337 2693
sales@italvibrasusa.com
www.italvibrasusa.com

■ **AUSTRALIA**

ITALVIBRAS AUSTRALIA PTY LTD.
Unti 2, Baile Road
tel. +61 8 6559 7470
fax +61 8 6230 4977
sales@italvibrasaustralia.com
www.italvibrasaustralia.com

**FOR OTHER COUNTRIES,
ASK US FOR THE LIST OF OUR DISTRIBUTORS**



ITALVIBRAS G. SILINGARDI SPA

41042 Fiorano Modenese MO Italy · via Ghiarola Nuova, 22/26
tel. +39 0536 804634 · fax +39 0536 804720
italvibras@italvibras.it · www.italvibras.com