

# News Assembly Components

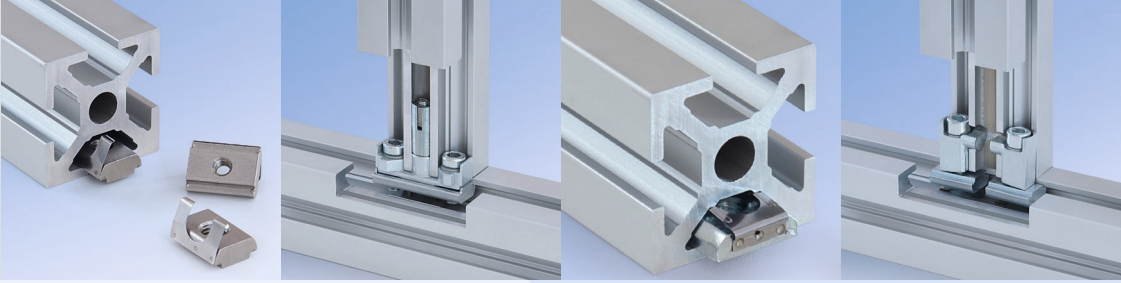

*Screw on  
and go*

*For  
retrofitting*

*Torsional rigidity  
for cleanrooms*

*Compact and  
super strong*

*Bouncy  
allrounders*

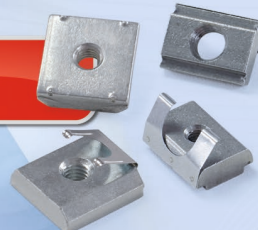

# Assembly Components

## Anchor fasteners

Screw on and go

The Anchor fastener is a patented, new fastener type that can be used without any profile services. The anchor fastener is inserted into the series 40  $\varnothing$  10 mm drilled hole and tensioned by means of a screw. The lateral anchors fix the fastener to the other profile, on the one hand, and ensure torsional rigidity, on the other.

SHCS M5 x 35, D0912535

Bushing outside, 06.00.0030

Clamp for anchor, 79.00.0050

Drop-in nut 2 M6 PE  
for anchor, 34.16.0636

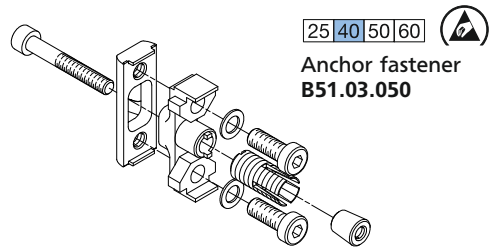
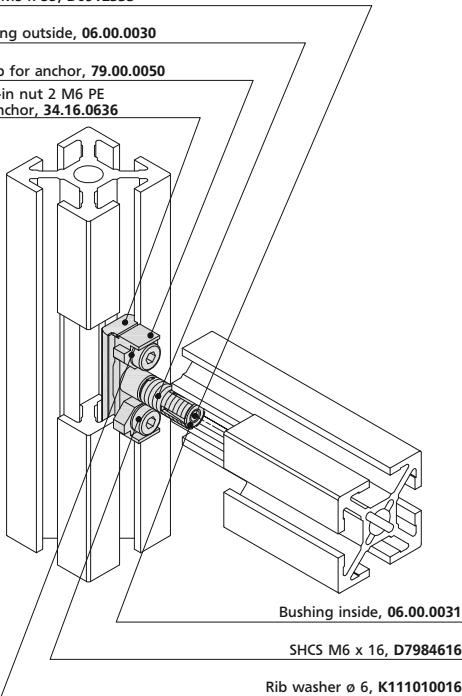

## Claw clamps

For retrofitting

Claw clamps are a versatile patented connector type for use with profiles of series 40 and 50. They allow for easy tightening of screws in the slots and provide the option of retrofitting; therefore they are suitable for a wide range of applications. They can be inserted into profiles with two, four, eight, or „n“ slots. For this type of connection, standard end machining with a drill hole of  $\varnothing 10$  mm and an edge spacing of 15 mm for series 40 and 14 mm for series 50 is required.

SHCS M6 x 25, D7984625

Rib washer, K111010016

Claw clamp with chamfer, 79.00.0060

Drop-in nut 1, 34.16.0631

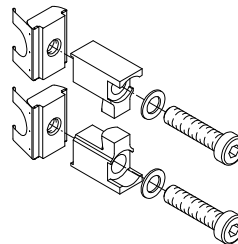
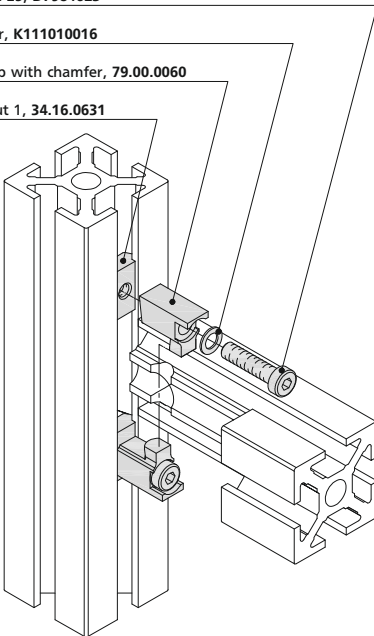

25 40 50 60



Claw clamp  
**B51.03.060**

Series 40

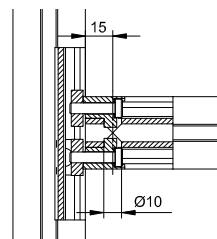

Series 50

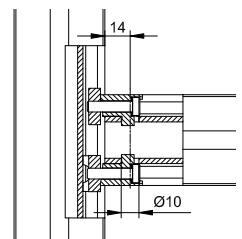

# Assembly Components

## Cleanroom fasteners

### Torsional rigidity for cleanrooms

Cleanroom fasteners are patented connectors by mk, which ensure torsional rigidity in addition to safe connection of series 40 cleanroom profiles. The fastener is clipped into the face side of a profile equipped with a threaded insert. By screw-fastening the profiles with each other, the connector is tensioned in the sealed slot and thus displaces the parting slot in that area. This results in particularly tight form closure.

SHCS M8 x 45, D6912845A2

Cleanroom fastener, 07.00.0039

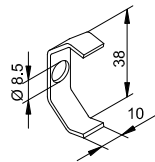
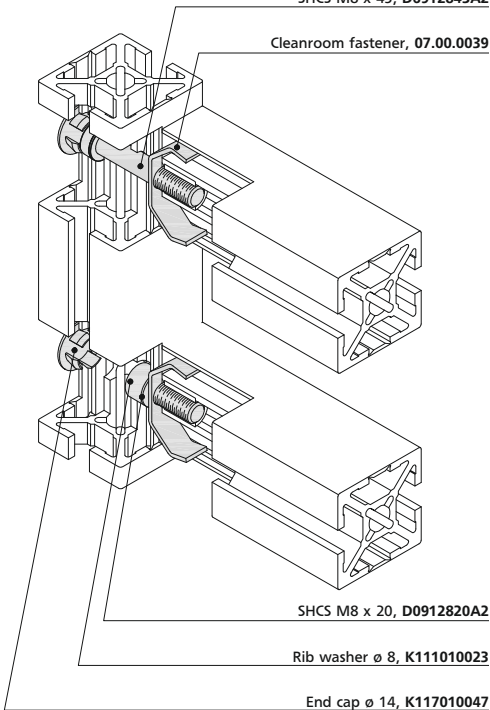

25 40 50 60



Cleanroom fastener,  
Stainless steel  
**07.00.0039**  
**B51.03.100**

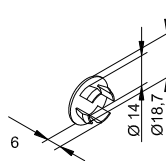

End cap for drilled  
hole  $\varnothing$  14 mm  
gray **K117010047**  
black **K117010048**  
beige **K117010049**

Instead of an end cap, a drop of adhesive can be used for sealing the drilled hole. The advantage is, that adhesive does not allow for dirt to be traps and thus is perfectly suitable for use e.g. in cleanrooms.

## Bolt fasteners

*Compact and super strong*

Bolt fasteners are compact and very robust connectors. They can be used in situations, where the interference contours of an angle needs to be avoided but without compromising stability of the connection. For the use of bolt fasteners, end machining with  $\varnothing 14$  mm at a distance of 20 mm from the edge is required. Thanks to the large range of variants, the fastener can be used with profile series 40 and 50.

Bolt fastener, 05.03.0019

Rib washer  $\varnothing 8$ , K1111010023

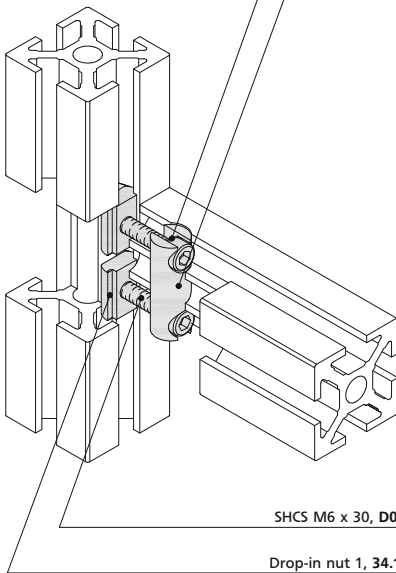

SHCS M6 x 30, D0912630

Drop-in nut 1, 34.16.0631

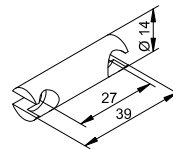

Bolt fastener 40

Steel Zn

**05.03.0019**

**B51.03.070**

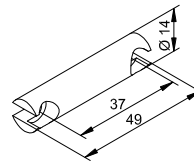

Bolt fastener 50

Steel Zn

**05.03.0020**

**B51.03.073**

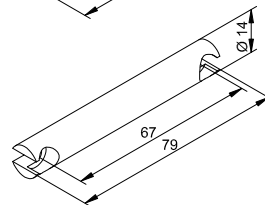

Bolt fastener 80

Steel Zn

**05.03.0021**

**B51.03.071**

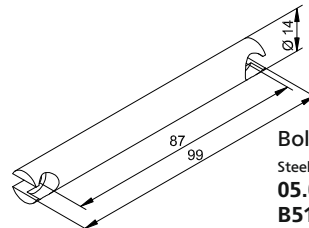

Bolt fastener 100

Steel Zn

**05.03.0022**

**B51.03.074**

# Assembly Components

## Nuts with spring steel sheet

### Bouncy allrounders

Nuts are the preferred mounting elements at mk in conjunction with angles, consoles, plates and T-slot accessory components. They are heavy-duty and tear-proof. The new variants of nut 1 are equipped with an additional spring steel sheet which fixes the nut in the profile slot and prevents it from sliding. Assembly of attachment elements vertically is much easier. In addition, the ESD variant ensures conductivity of the connection.

Drop-in nuts from mk are intended for later insertion in the profile slot e.g. if the front of the profile is already closed and the nuts 1 can no longer be inserted. The new variants are made of stainless steel and thus are corrosion-resistant.

### Installation situation for drop-in nuts

#### Series 40

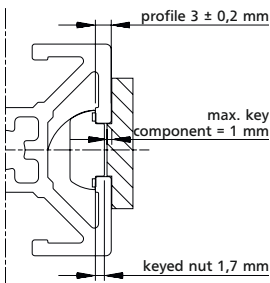

#### Series 50

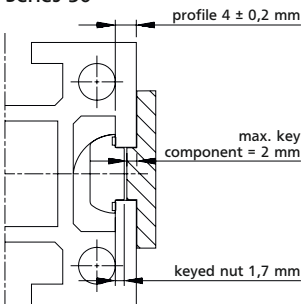

The key height of the component to be fastened, e. g. an angle, must not exceed 1 mm with series 40 or 2 mm for series 50, since otherwise force closure between the profile and the nut is not properly obtained.

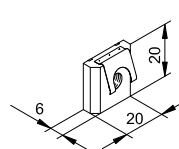

25 40 50 60



#### Nut 1

Steel Zn,  
with spring steel sheet, ESD

M6 34.02.0050

M8 34.01.0050

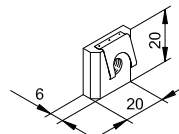

25 40 50 60

#### Nut 1

Steel Zn,  
with spring steel sheet

M6 34.02.0051

M8 34.01.0051

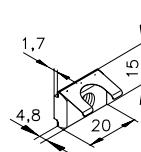

25 40 50 60



#### Drop-in nut 1





Stainless steel,  
with spring steel sheet, ESD

M5 34.16.0537

M6 34.16.0637

M8 34.16.0837

# Selection of assembly components

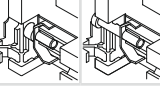
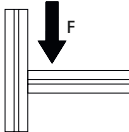
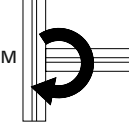
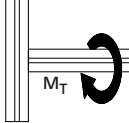
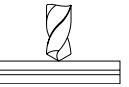
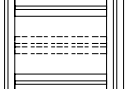
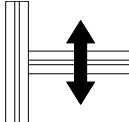
										
		Angle (one side)	Angle (two sides)	Anchor fasteners	Claw clamps		Bolt fasteners		Cleanroom fasteners	
					Profiles 40 x 40	Profiles 50 x 50	Profiles 40 x 40	Profiles 50 x 50		
	Force-bearing capacity	1000 N	2000 N	1200 N	1200 N	1200 N	1200 N	1200 N	900 N	900 N
	Moment of resistance	200 Nm	250 Nm	40 Nm	50 Nm	70 Nm	60 Nm	80 Nm	20 Nm	70 Nm
	Moment of torsional resistance	20 Nm	80 Nm	5 Nm	10 Nm	15 Nm	15 Nm	20 Nm	15 Nm	20 Nm
	End machining	none	none	none	∅ 10 mm	∅ 10 mm	∅ 14 mm	∅ 14 mm	Stepped drill hole ∅ 14/9 mm	Stepped drill hole ∅ 14/9 mm
	Retrofitting assembly between profiles	yes	yes	no	yes	yes	yes	yes	no	no
	Subsequent shifting	yes	yes	yes	yes	yes	yes	yes	no	no

Screw size	M5	M6	M8
Pre-tension force [N]	6000	9000	16500
Tightening torque [Nm]	6	10	25
Max. operating force in axial direction (static) [N]	1800	2500	4800
Max. operating force in axial direction (dynamic) [N]	900	1500	3400
Friction closure max. [N]	400	630	1100

The specified values are applicable for screws of strength category 8.8 with  $\mu = 0.14$ . The operating force values apply for centered forces in axial direction. Tightening factors must be separately taken into account.

Other than the maximum values from applicable literature, the maximum values for operating force and friction closure include a safety factor of  $s_0 \geq 2$  (for static and oscillating loads). Other safety factors are recommended for changing load directions  $s_0 \geq 3$ , for dynamic loads  $s_0 \geq 4$ , and for vibrations and impacts  $s_0 \geq 5$ .



**Maschinenbau Kitz GmbH**  
**Headquarters of the**  
**mk Technology Group**

Glockenstraße 84  
53844 Troisdorf  
Germany

Phone +49 228 4598-0  
Fax +49 228 453145

[www.mk-group.com](http://www.mk-group.com)  
[info@mk-group.com](mailto:info@mk-group.com)